



ImagePro 9017  
Video/Cinema/Data  
DILA Projector

- 1500 lumen brightness
- SXGA plus resolution
- Film like image
- Professional color fidelity
- All the necessary features

**Exclusive five year warranty**  
the best warranty in the industry

- Education
- Business
- Home Theater



9017  
**DUKANE**

# ImagePro 9017 Video/Cinema/Data DILA Projector

## A new set of options for the future

The Dukane ImagePro 9017 is the professional projector that combines the color accuracy, image quality, and resolution needed when a truly outstanding viewing event is required. From small fonts to high resolution graphics, computer images can be projected in a form that compares to the best monitors.

In addition, video images including all forms of HDTV can be displayed in superb color, contrast, and resolution. A compact size and exceptional feature set make this the ideal projector for technical applications such as training, board-rooms, seminars, or an outstanding home theater.



### Key features:

- True SXGA+ Resolution (1400 x 1050)
- DILA Technology for film like images
- Excellent Color Fidelity matches your source
- Third generation scaling and deinterlacer to provide the perfect image
- 1500 ANSI lumens at 800 to1 contrast
- Compatible with all video, including HDTV, plus computer images
- Portable and compact at only 13 lbs.
- "Custom Image" for your startup and blank screens
- "Silent Running" so you hear only your message
- Vertical and horizontal keystone correction
- New 2000 hour lamp life
- Multiple inputs for maximum flexibility

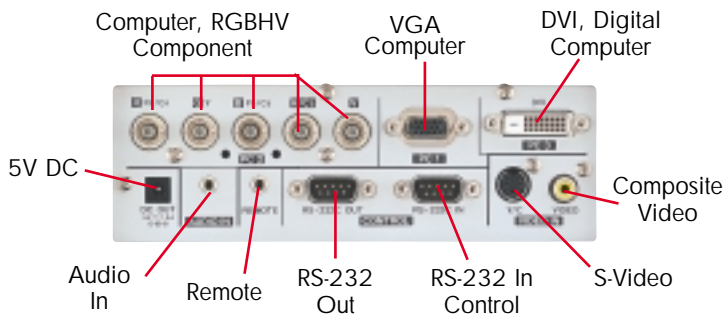

# DUKANE

Dukane Corporation  
Audio Visual Products Division  
2900 Dukane Drive  
St. Charles, Illinois 60174  
800-676-2485 toll-free  
630-584-5156 fax  
avsales@dukane.com e-mail  
www.dukcorp.com/av

ImagePro is a registered trademark of Dukane Corporation  
#11586-C-03

## Specifications

DILA Type	0.7" x 3, Direct Image Light Amplifier
Brightness	1500 ANSI lumens
Resolution	1400 x 1050 pixels (H X V), 1000 TV lines
Contrast	800:1
Scanning Frequency	fh 15 -120 kHz, fv 24, 25, 30, 50 -120 Hz
Data Clock	230 mHz
Lens	Manual zoom ( f2.1 -2.61), 1.3x
Lens Throw Ratio	1.9 – 2.5:1 throw distance to image width
Keystone Correction	Digital, +/-30° V, +/-10° H
Aspect Ratio	4:3, 16:9, selectable
Computer	VGA, SVGA, XGA, SXGA, UXGA, PC and Mac
Video Compatibility	NTSC, PAL, SECAM, NTSC 4.43, HDTV 480p, 576p, 720p @60, 1080i (50,60), 1035i @60, 1080i (24, 25, 30), 1080p (24, 25, 30)
Image Control	Freeze frame, 16 x digital zoom and pan
Projection Modes	Front/rear/ceiling
Color Profile Modes	RGB, Mac, Adobe, EBU broadcast
Lamp	250W, NSH
Lamp Life	2000 hours (typical)
Audio	Speaker 1 watt monaural
Throw Distance	5.2ft. to 40ft.
Image Size	2.6ft. to 20ft.
Inputs, Video	(1) Component, BNC x 3 (1) S-video, Min DIN (1) Composite, RCA (1) Audio, mini jack
Inputs, Computer	(1) Digital DVI (2) RGBHV, BNC x 5 share with component, and a 15pin D-sub
Control	(1) Input serial, RS-232, 9pin D-sub (1) Output serial, RS-232, 9pin D-sub
Output Voltage	Terminal, 5V DC @ 1.5A
Wired Remote	Mini jack
Fan Level	Ultra quiet
Power	100-240 VAC, 50/60 Hz, 340 watt
Size (WxHxD)	11.7" x 5" x 15"
Weight	13 lbs.
Shipping Weight	21 lbs.
Carton Size	19.5" x 12.8" x 22.5"
Accessories Included	Remote control, batteries, power cord, computer cable, operators manual.
Safety	UL/CUL, EMC Class B
Optional Accessories	Lamp 456-239

## Five (5) year limited warranty

on parts and labor in North America, lamp excluded  
(for other locations, local warranties apply).

Includes Dukane's FREE 24 month  
Peace-of-Mind Loaner Program.

# 5YR